

# The demonstration and operation of a vanadium flow battery system for microgrid application

Shohei Fukumoto<sup>1\*</sup>, Masao Moriguchi<sup>1</sup>, Takuya Sano<sup>1</sup>, Toshikazu Shibata<sup>1</sup>, François Henry<sup>2</sup>, Hamid Soleimani Bidgoli<sup>2</sup>

<sup>1</sup> Energy Systems Division, Sumitomo Electric Industries, Ltd., Osaka, Japan

<sup>2</sup> John Cockerill Energy, John Cockerill, Seraing, Belgium

Email: fukumoto-shohei@sei.co.jp

## Introduction

A 1.7MWh Vanadium Flow Battery (VFB) system was installed into John Cockerill (JC)'s microgrid demonstration system which is named "Micro Réseau Intégré Seraing (MiRIS)". The system has been operated to demonstrate on-grid and off-grid. In this paper, the outline of this project and some of the results of the demonstration are described.

## Background

Sumitomo Electric Industries, Ltd. (SEI) has recently installed VFB systems for the grid stabilization applications, such as 60 MWh system in Hokkaido, Japan for frequency control<sup>[1]</sup> and 8 MWh system in San Diego, USA for energy market application<sup>[2]</sup>. In addition to these applications, Battery Energy Storage Systems (BESS) for microgrid applications are currently drawing a lot of attention as Distributed Energy Resource (DER) for C&I's BCP, local distribution network and areas without electricity. In this background, SEI and JC installed the 500 kW (1.7 MWh) VFB system into JC's MiRIS, the largest industrial energy storage station, in Belgium.

## VFB System Configuration

The VFB system has an output power 500 kW and an energy capacity of 1.7 MWh. The system appearance is shown in Figure 1. The system is fully containerized and this system configuration contributes to footprint reduction as well as less transportation costs and less installation work, in comparison to that of the conventional plant system, which consists of tank, electrolyte circulation, auxiliary system and cell stacks separately.



Figure 1. VFB system appearance.

## MiRIS Configuration

The schematic diagram of MiRIS is shown in Figure 2. MiRIS hosts Photovoltaic (PV) units, BESSs, diesel generators and loads for the demonstration of off-grid applications. The VFB demonstration was performed both on-grid and off-grid operation in MiRIS. The VFB system is able to deliver the requested active/reactive powers in on-grid mode for energy management purposes, and ensure the stability of MiRIS in off-grid situations.

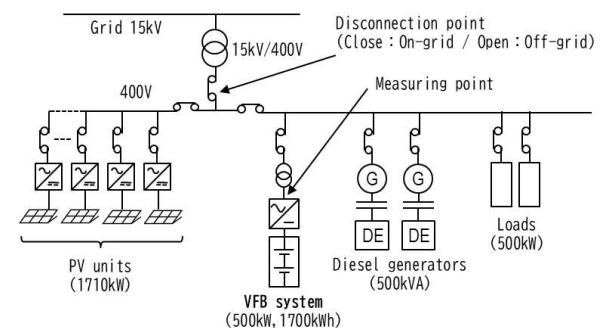

Figure 2. MiRIS schematic and measuring point.

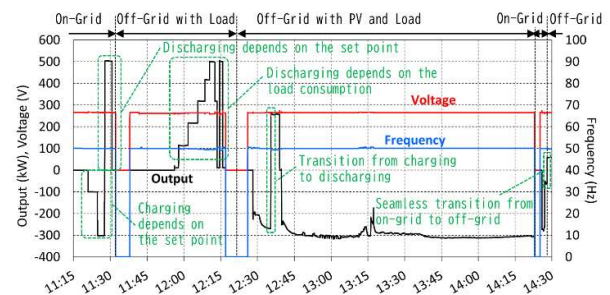

Figure 3. Operation test results at on- and off-grid mode.

## VFB Operation at On- and Off-grid Mode

The example results of operation test at both on-grid and off-grid mode is shown in Figure 3. At on-grid operation, the VFB system was successfully charged or discharged from or to the grid according to the set-points value with fast response time and sufficient power quality, which enables the peak shaving and demand response applications. After disconnection from the grid, the VFB system acted as voltage source and maintained the frequency and the voltage of the

MiRIS microgrid. Even with up to 500 kW of sudden load fluctuation, the VFB system compensated very well and the power quality was very stable. When the 300 kW PV was connected to it, the excess power of PV was charged to the VFB system according to PV's power fluctuations and kept the frequency and voltage of microgrid within the proper range. The seamless transition from on-grid to off-grid operation was also successfully operated without any power outage.

### Power Quality

The voltage and frequency trends for VFB's charge/discharge power at on-grid and off-grid operation are shown in Figure 4. The VFB system takes a roll of the voltage source at off-grid mode. As a result, it was confirmed that the voltage fluctuation was kept within 2 %, which is sufficient quality, despite of the sudden change of load consumption and PV power. Assuming the VFB system operated in parallel with generators during off-grid, the frequency control with droop method is applied. As a results, it is confirmed that the frequency trend for the VFB output was corresponded to the droop setting of 2%.

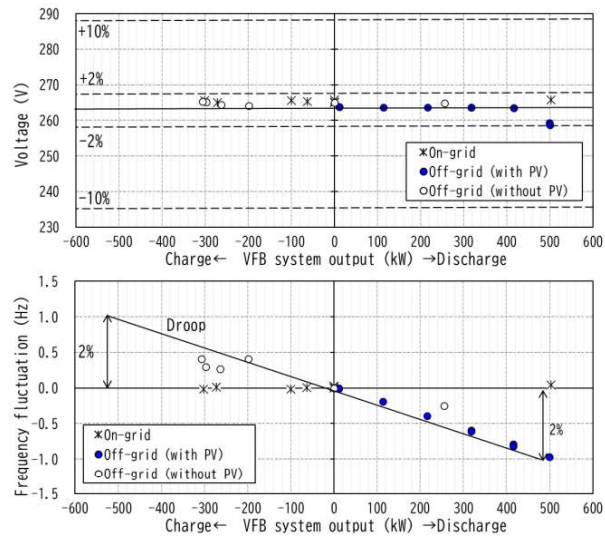

Figure 4. Voltage and frequency in on-grid and off-grid operation.

### Acknowledgements

These results were obtained through joint demonstration with John Cockerill, and we would like to express our gratitude to all concerned parties.

### References

- [1] T. Shibata et al., "Performance evaluation of a 60MWh vanadium flow battery system over three years operation", *Proc. of International Flow Battery Forum 2019*, pp. 134-135
- [2] Y. Nagaoka et al., "A pilot project using a VFB in multiple-use application", *Proc. of International Flow Battery Forum 2018*, pp. 92-93

### Transition Characteristics

The transient characteristic from charging to discharging is shown in Figure 5. The current phase was changed within a cycle and it reached to the setting point within 120 ms. The sufficient transient characteristics for practical use were demonstrated.

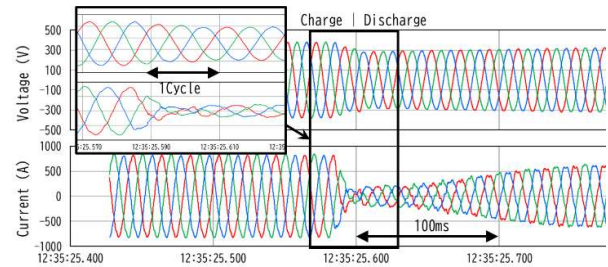

Figure 5. Transient characteristic at transition from charging to discharging.

### Seamless Transition from On-Grid to Off-Grid

The seamless transition from on-grid to off-grid operation is required for the micro-grid function in the event of power outage. As shown in Figure 6, the VFB system achieved the seamless and instant transition from on-grid to off-grid operation without disturbance of the voltage waveform.

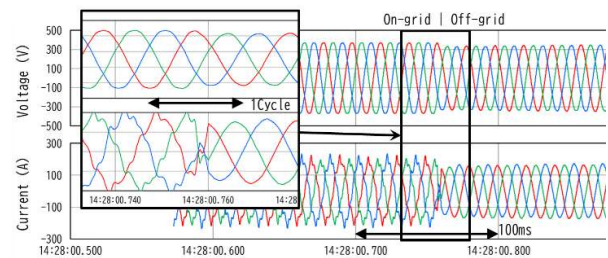

Figure 6. Transient characteristic at transition from on-grid to off-grid.

### Conclusion

The fundamental results for the microgrid operation by VFB system as voltage source, such as power quality, stability, response speed and transition characteristics, were demonstrated through MiRIS.

We believe these results will contribute to the further application of VFB system to Distributed Energy Resource (DER) for C&I's BCP, local distribution network and microgrid for areas with no electricity.